



# 6455-C

## FROZEN BEVERAGE FREEZER

Two flavor, Countertop, Gravity feed

### Most **Compact & Versatile**

Two flavor countertop model for frozen beverage and smoothies

#### **Fast Freeze Down**

Patented high efficiency heat exchanger allows fast freeze down with low energy consumption

#### **Simple Control, Easy Operation**

Simple and intuitive control system makes operation and viscosity adjustment easy, swift and more precise

#### **Low Mix Indicator**

Light turns "ON" at low mix to alert operator to add mix

#### **See-through Dispensing Door**

Clear dispensing door design makes product more attractive and serves as great marketing tool

#### **Standby & Indicator**

Maintains product temperature in both mix hopper and freezing cylinder below 4.4°C (40°F) overnight; Indicator light turns ON blue under Standby mode

Perfect solution for alcoholic and non-alcoholic frozen beverages in bars, restaurants, hospitals, schools and kiosks



#### **Hopper Agitators**

Maintain product consistency and prevent product separation

#### **Self-closing Dispensing Valves**

Automatically prevents product overflow after dispense

#### **Safety Protections**

- High pressure switch to prevent compressor overheating
- Thermal overload to protect from motor overheating

#### **Light Box (Optional)**

- Illuminates flavor cards to attract more business
- Changes color to indicate Low Mix and Standby

#### **One-hand Operated Spinner (Optional)**

- Adds ability to blend and offer more varieties of treats
- Allows for multi-tasking one-hand operation that helps increase productivity and reduce serving time



# 6455-C

## FROZEN BEVERAGE FREEZER

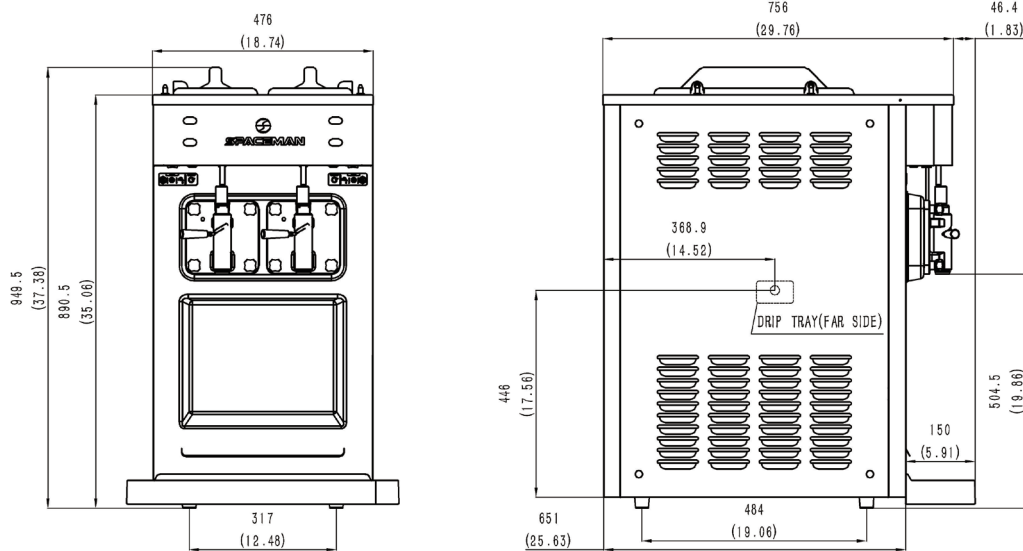

### SPECIFICATIONS

Flavors	2
Freezing Cylinders	2 x 3.8L / 4.0qt
Mix Hoppers	2 x 8.0L / 8.5qt
Output Capacity (8oz)	240 servings/hr
Clearance Requirements	152mm/6" on back

### Weight Kg/lb

Net	146 / 325
Shipping	166 / 369
Volume	0.48 CBM / 17.10 CBF

### Dimensions Net (mm/in) Shipping (mm/in)

Width	476 / 18.7	520 / 20.5
Depth	651 / 25.6	853 / 33.6
Height	950 / 37.4	1090 / 42.9

### Electrical MFS MCA Power(kW)

220-240/50/1	15	13	2.0
220-240/60/1	15	13	2.1
110-115/60/1	20	16	1.6

### FEATURES

Control Systems	Two, Mechanical
Refrigerated Hoppers	✓
Hopper Agitators	✓
Standby Mode	✓
Auto Closing Dispensing Valves	✓
Low Mix Indicator Light	✓
Low Mix Indicator Alarm	✓
Standby Mode	✓
Standby Indicator Light	✓
High Pressure Protection	✓
Thermal Overload Protection	✓

### AVAILABLE OPTIONS

Top Air Discharge Chute	✓
Spinner	✓
Light Box	✓

• Above specifications are subject to change without notice